

REVISION RECORD				
REV	ECN#	DESCRIPTION	BY	DATE
A0			Lxj	



**QuickTAC Stock 2 Strand 1000FT Tactical Singlemode Fiber Optic Cable Assembly  
w/ LC UPC Connectors, Connector Sleeves, and Cable Bale Pre-Installed on a Heavy Duty Deployable Reel w/ Auxiliary Spool**

Side A

**BUILD SPECIFICATIONS**

Side B

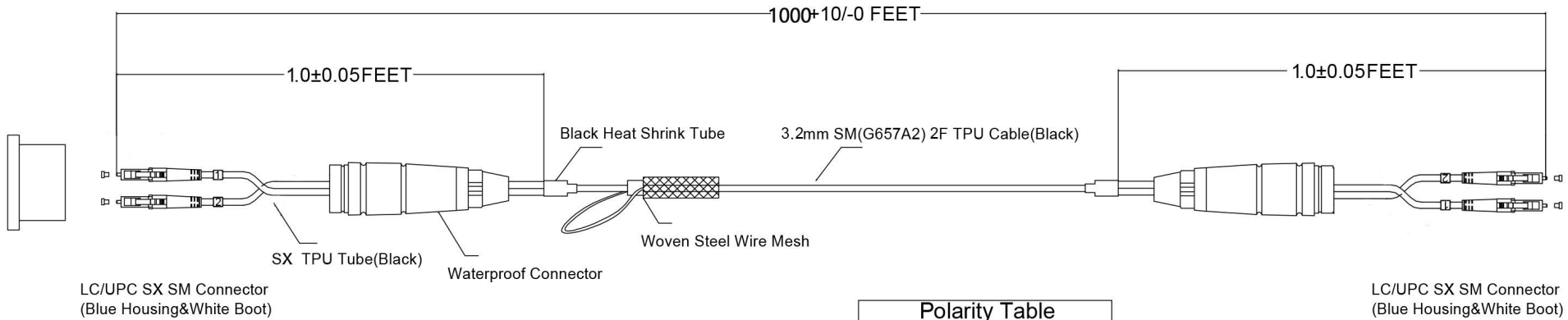

Side A	Fiber	Side B
LC No. Ring		LC No. Ring
1	Fiber 1	1
2	Fiber 2	2

1.  $IL \leq 0.3dB$   $RL \geq 50dB$  1310nm&1550nm
2. Other requirements of the product meet IEC standards
3. Dual-flange reel: metal grip end on outside, no metal grip end on inside

Purchase at **LANshack.com**  
 sales@LANshack.com • 888-568-1230

**Title:** QuickTAC Stock 2 Strand 1000FT Tactical Singlemode Fiber Optic Cable Assembly w/ LC UPC Connectors, Connector Sleeves, and Cable Bale Pre-Installed on a Heavy Duty Deployable Reel w/ Auxiliary Spool by QuickTrex®  
**SKU:** QT-QTAC-SM-2F-1000FT-LCU-CCBR

<b>Unit: MM</b>		<b>Drawer</b>		<b>Approve</b>	
<b>X</b>	<b>X° -</b>	<b>Lxj</b>		<b>Xbf</b>	
<b>X.X</b>	<b>X.X° -</b>	<b>Proportion</b>	<b>Unit</b>	<b>Quantity</b>	<b>Page</b>
		<b>NA</b>	<b>mm</b>	<b>1pc</b>	<b>1/1</b>
					<b>THIRD ANGLE PROJECTION</b>

